



ECP 200 EXPERT



USE AND MAINTENANCE MANUAL

CONTENTS

INTRODUCTION

Page 4	1.1	General
Page 4	1.2	Product ID codes
Page 5	1.3	Overall dimensions
Page 5	1.4	Identification data

CHAP. 1

INSTALLATION

Page 6	2.1	Important information for the installer
Page 6	2.2	Standard assembly kit
Page 7	2.3	Installing the unit

CHAP. 2

FUNCTIONS

Page 9	3.1	ECP200 EXPERT panel functions
--------	-----	-------------------------------

CHAP. 3

TECHNICAL CHARACTERISTICS

Page 10	4.1	Technical characteristics
Page 11	4.2	Warranty

CHAP. 4

PARAMETER PROGRAMMING

Page 11	5.1	Control panel
Page 11	5.2	Frontal keypad
Page 12	5.3	LED display
Page 13	5.4	General
Page 13	5.5	Key to symbols
Page 13	5.6	Setting and displaying set points
Page 14	5.7	Level 1 programming
Page 15	5.8	List of Level 1 variables
Page 16	5.9	Level 2 programming
Page 16	5.10	List of Level 2 variables
Page 18	5.11	Switching on the ECP200 BASE electronic controller
Page 18	5.12	Compressor activation/deactivation conditions
Page 19	5.13	Manual defrosting
Page 19	5.14	Hot gas defrosting
Page 19	5.15	Pump down function

CHAP. 5

OPTIONAL

Page 21	6.1	<i>TeleWIN- TeleNET</i> monitoring / supervision system
Page 22	6.2	<i>ALARM RELAY / TeleWIN- TeleNET</i> switching

CHAP. 6

TROUBLESHOOTING

Page 23	7.1	Troubleshooting
---------	-----	-----------------

CHAP. 7

ALLEGATI / APPENDICES

Page 24	A.1	EC declaration of conformity
Page 25	A.2	ECP200 EXPERT wiring diagram
Page 26	A.3	TeleWIN – TeleNET network connection diagram
Page 27	A.4	Part list

CHAPTER 1: INTRODUCTION

1.1

GENERAL

DESCRIPTION:

The **ECP200 EXPERT** is a new control panel for cold rooms with a single-phase compressor up to 2 HP, specially designed to provide the user with safety, protection, control and ease of installation.

It allows the user to control all the components on a refrigerating system: compressor, evaporator fans, defrosting elements, room light and thermostat-holder demisting element.

APPLICATIONS:

- Complete management of single-phase static or ventilated refrigeration systems up to 2 HP, with off-cycle or electrical defrosting and with direct or pump-down compressor stop.
- Control of single-phase evaporator unit only with freon solenoid consensus or remote condensing unit consensus.

MAIN CHARACTERISTICS:

- Direct control of defrosting elements, evaporator fans, room light with outputs directly connectable to the various units.
- Magneto-thermal cut-out switch for isolation and protection of the refrigeration unit.
- Innovative, smartly designed ABS cover with transparent cover for access to the magneto-thermal cut-out switch, all with an IP65 protection rating so that panel can be used outside the room.
- LED indicators and large display illustrate system status.
- User-friendly keypad.
- Auxiliary relay with parameter-configured activation (alarms, temperature set point, direct control via front push-button, thermostat-holder demisting element, remote condensing unit consensus, freon solenoid control in the event of compressor pump-down operation).
- Possibility, as an alternative to an auxiliary relay, of a RS485 port for connection to the TeleWIN supervision network (industrial TeleNET for local networks without instrument limits).
- Temperature control to 0.1 °C.

1.2

PRODUCT ID CODES

ECP200 EXPERT

controls and manages compressor, defrosting elements, evaporator fans and room light. Aux/Alarms relay

OVERALL DIMENSIONS

1.3

Dimensions (mm.)



IDENTIFICATION DATA

1.4

The unit described in this manual has an ID plate on the side showing all the relevant identification data:

- Name of Manufacturer
- Code and model of unit electrical board
- Serial number
- IP protection rating
- Power supply



CHAPTER 2: INSTALLATION

2.1

IMPORTANT INFORMATION FOR THE INSTALLER

1. Install the device in places where the protection rating is observed and try not to damage the box when drilling holes for wire/pipe seats.
2. Do not use multi-polar cables in which there are wires connected to inductive/power loads or signalling wires (e.g. probes/sensors and digital inputs).
3. Do not fit power supply wiring and signal wiring (probes/sensors and digital inputs) in the same raceways or ducts.
4. Minimise the length of connector wires so that wiring does not twist into a spiral shape as this could have negative effects on the electronics.
5. Fit a general protection fuse upstream from the electronic controller.
6. All wiring must be of a cross-section suitable for relevant power levels.
7. When it is necessary to make a probe/sensor extension, the wires must have a cross-section of at least 1 mm².

2.2

STANDARD ASSEMBLY KIT

For the purposes of assembly and use, the electronic **ECP200 EXPERT** control unit comes with:

- N° 3 seals, to be fitted between the fixing screws and the box back panel
- N° 1 user's manual.

INSTALLING THE UNIT

2.3

Fig. 1: Raise the transparent cover that shields the magneto-thermal cut-out switch and remove the screw cover on the right-hand side.



Fig. 2: Undo the 4 fixing screws at the front of the box.



Fig. 3: Close the transparent cut-out switch cover.



Fig. 4: Open the front of the box, lift it and slide the two hinges out as far as they will go.



Fig. 5: Press on the sides of the hinges to remove them from their seats and so remove the front panel completely.

Fig. 6: Use the three existing holes to fix the box back panel to the wall: use three screws of a length suitable for the thickness of the wall to which the panel will be attached. Fit a rubber washer (supplied) between each screw and the box backing.

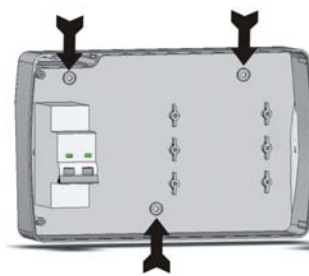
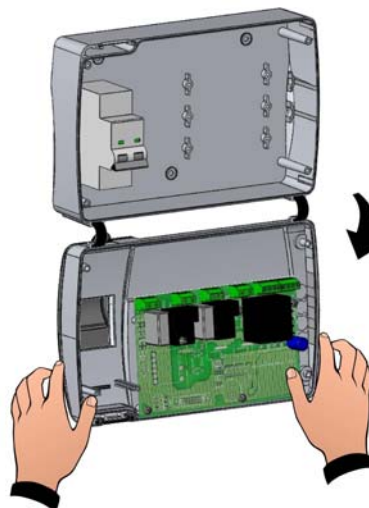

Fig. 7: Hook the frontal panel back up to the lower part of the box by inserting the two hinges in their seats and, bending them, rotate downwards 180° to gain access to the electronic board.



Make all the electrical connections as illustrated in the diagram for the corresponding model (see relative table in APPENDICES).

To effect correct electrical connection and maintain the protection rating, use appropriate wire/raceway grips to ensure a good seal.

Route the wiring inside the unit in as tidy a fashion as possible: be especially careful to keep power wires away from signal wires. Use clips to hold wires in place.



Fig. 8: close the front panel, making sure that all the wires are inside the box and that the box seal sits in its seat properly.

Tighten the front panel using the 4 screws, making sure the O-rings on the head of each screw are used.

Power up the panel and carry out thorough reading/programming of all the parameters.



Be careful not to over-tighten the closure screws as this could warp the box and compromise proper operation of the membrane-type keypad.

Install short-circuit overload safety devices on all the power cables connected to the ECP200 EXPERT so as to prevent damage to the device. Work and/or maintenance must ONLY be carried out on the unit after disconnecting the panel from the power supply and from any inductive/power loads: doing so allows the worker to do his job safely.



CHAPTER 3: FUNCTIONS

3.1

ECP200 EXPERT PANEL FUNCTIONS

- Display and adjustment of cold room temperature accurate to 0.1 °C.
- Display of evaporator temperature from parameter
- System control activation/deactivation
- System warnings (probe/sensor errors, minimum and maximum temperature warnings, compressor shutdown)
- Evaporator fans control
- Automatic and manual defrost (static, heating element, cycle inversion)
- Direct control of compressor unit up to 2 HP
- Room light, via panel key or door switch
- Alarms/auxiliary relay

CHAPTER 4: TECHNICAL CHARACTERISTICS

TECHNICAL CHARACTERISTICS

4.1

Power supply	
Voltage	230 V~ ± 10% 50Hz / 60Hz
Max power (only electronics)	~ 7 VA
Cold room conditions	
Working temperature	-5 ÷ 50°C
Storage temperature	-10 ÷ 70°C
Relative humidity	Less than 90%
General characteristics	
Type of sensors that can be connected	NTC 10K 1%
Resolution	0,1 °C.
Sensor read precision	± 0,5 °C
Read range	-45...+45 °C
ECP200 EXPERT - Output characteristics - max applicable load (230 V AC)	
Compressor	1500W (AC3)
Elements	3000W (AC1)
Fans	500W (AC3)
Room light	800W (AC1)
Alarm contact (non-powered contact)	100W
General electrical protection	Magneto-thermal cut-out switch Bi-polar 16A Id=300 mA Disconnecting power 4.5 kA
Dimensional characteristics	
Dimensions	16.8 cm x 9.7 cm x 26.2 cm (HxPxL)
Insulation / mechanical characteristics	
Box protection rating	IP65
Box material	Self-extinguishing ABS
Type of insulation	Classe II

4.2

WARRANTY

The electronic controllers in the **ECP200 EXPERT** are covered by a 24-month warranty against all manufacturing defects, valid from date of delivery. If the system malfunctions as a result of tampering, impact or improper installation the warranty will automatically be rendered null and void. It is strongly recommended that you observe all instructions/information regarding the technical characteristics of the device.

**WARNING !**

Any modifications made to wiring and/or internal components or any work carried out in a way that fails to comply with the information/instructions in this manual shall render the warranty null and void immediately. Modifications/improper work may cause malfunctions, irreparable damage, serious injury or put persons/objects in danger.



PEGO S.r.l. cannot be held liable for possible errors or inaccuracies written in this manual as a result of printing or transcription errors.

PEGO S.r.l. reserves the right to modify its products as it deems necessary without altering its main characteristics. Each new release of a **PEGO** user manual replaces previous ones.

CHAPTER 5: PARAMETER PROGRAMMING

CONTROL PANEL





5.1

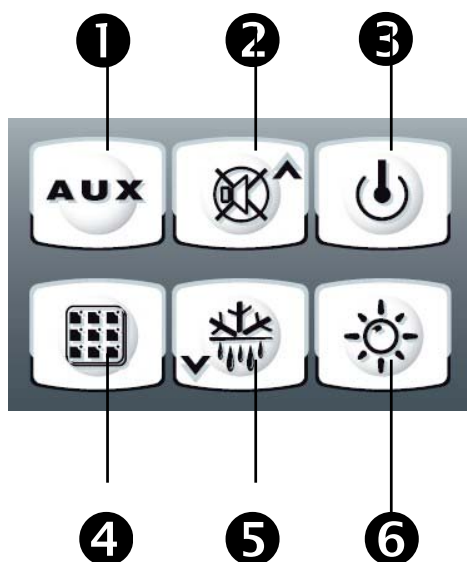

FRONT KEYPAD

5.2



1. **AUX** key: **AUXILIARY RELAY CONTROL** (on the version with alarm relay controls the relay manual if parameter AU=1)
2.  key: **UP / MUTE WARNING BUZZER**
3.  key: **STAND BY** (if the system shuts down the LED flashes)
4.  key: room temperature **SETTING**
5.  key: **DOWN / MANUAL DEFROST**
6.  key: **ROOM LIGHT**

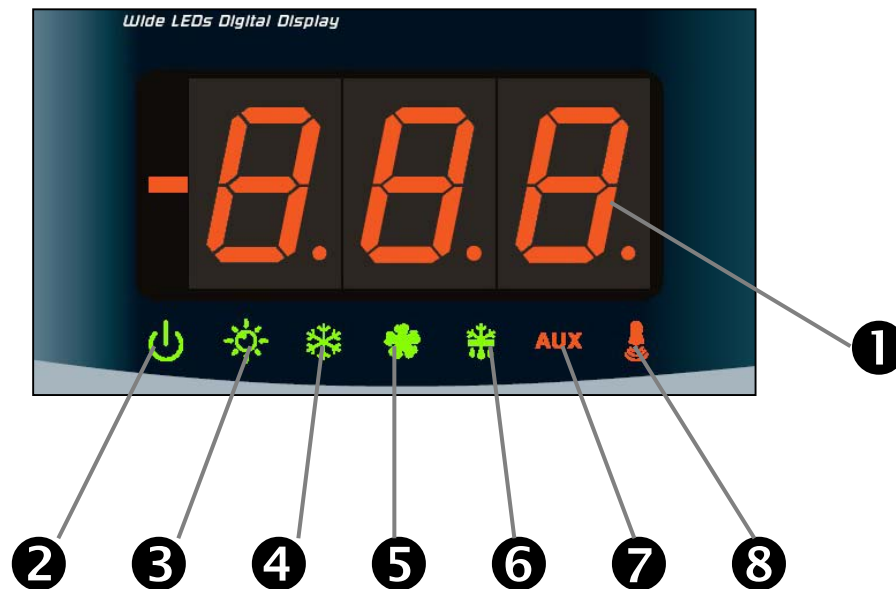

1. Cold room temperature / parameters
2. Stand-by (flashes on stand-by. Outputs are deactivated)
3. Room light (flashes if door switch activated)
4. Cold (indicates activation of compressor)
5. Fans
6. Defrosting
7. Auxiliary
8. Alarm/warning

5.4

GENERAL



To enhance safety and simplify the operator's work, the **ECP200 EXPERT** has two programming levels; the first level (Level 1) is used to configure the frequently-modified **SETPOINT** parameters. The second programming level (Level 2) is for general parameter programming of the various controller work modes.

It is not possible to access the Level 2 programming directly from Level 1: you must exit the programming mode first.

5.5

KEY TO SYMBOLS

For purposes of practicality the following symbols are used:

- (▲) the UP key  is used to increase values and mute the alarm.
- (▼) the DOWN key  is used to decrease values and force defrosting.

5.6

SETTING AND DISPLAYING THE SET POINTS

1. Press the **SET key** to display the current **SETPOINT** (temperature)
2. Hold down the **SET key** and press the (▲) or (▼) keys to modify the **SETPOINT**.

Release the **SET key** to return to cold room temperature display: the new setting will be saved automatically.

To gain access to the Level 1 configuration menu proceed as follows:

1. Press the (▲) and (▼) keys simultaneously and keep them pressed for a few seconds until the first programming variable appears on the display.
2. Release the (▲) and (▼) keys.
3. Select the variable to be modified using the (▲) or (▼) key.
4. When the variable has been selected it is possible:
 - to display the setting by pressing SET key
 - to modify the setting by pressing the SET key together with the (▲) or (▼) key.

When configuration values have been set you can exit the menu by pressing the (▲) and (▼) keys simultaneously for a few seconds until the cold room temperature reappears.

5. The new settings are saved automatically when you exit the configuration menu.

5.8

LIST OF LEVEL 1 VARIABLES (User level)

VARIABLES	MEANING	VALUE	DEFAULT
<i>r0</i>	Temperature difference compared to main SETPOINT	0.2 - 10 °C	2°C
<i>d0</i>	Defrost interval (hours)	0 - 24 hours	4 hours
<i>d2</i>	End-of-defrost setpoint. Defrost is not executed if the temperature read by the defrost sensor is greater than <i>d2</i> (If the sensor is faulty defrosting is timed)	-35 - 45 °C	15°C
<i>d3</i>	Max defrost duration (minutes)	1 - 240 min	25 min
<i>d7</i>	Drip duration (minutes) At the end of defrost the compressor and fans remain at standstill for time <i>d7</i> , the defrost LED on the front panel flashes.	0 - 10 min	0 min
<i>F5</i>	Fan pause after defrost (minutes) Allows fans to be kept at standstill for a time <i>F5</i> after dripping. This time begins at the end of dripping. If no dripping has been set the fan pause starts directly at the end of defrost.	0 - 10 min	0 min
<i>A1</i>	Minimum temperature alarm Allows user to define a minimum temperature for the room being refrigerated. Below value <i>A1</i> an alarm trips: the alarm LED flashes, displayed temperature flashes and the buzzer sounds to indicate the problem.	-	-45°C
<i>A2</i>	Maximum temperature alarm Allows user to define a maximum temperature for the room being refrigerated. Above value <i>A2</i> an alarm trips: the alarm LED flashes, displayed temperature flashes and the buzzer sounds to indicate the problem.	-	+45°C
<i>tEu</i>	Evaporator sensor temperature display	Displays evaporator temperature (displays nothing if dE =1)	read only

LEVEL 2 PROGRAMMING (Installer level)

5.9

To access the second programming level press the UP (▲) and DOWN (▼) keys and the LIGHT key simultaneously for a few seconds.

When the first programming variable appears the system automatically goes to stand-by.

1. Select the variable to be modified by pressing the UP (▲) and DOWN (▼) keys.

When the parameter has been selected it is possible to:

2. View the setting by pressing the SET key.

3. Modify the setting by holding the SET key down and pressing the (▲) or (▼) key.

4. When configuration settings have been completed you can exit the menu by pressing the (▲) and (▼) keys simultaneously and keeping them pressed until the room temperature reappears.

5. Changes are saved automatically when you exit the configuration menu.

6. Press the STAND-BY key to enable electronic control.

LIST OF LEVEL 2 VARIABLES (Installer level)

5.10

VARIABILI	SIGNIFICATO	VALORI	DEFAULT
VARIABLES	MEANING	VALUES	DEFAULT
AC	Door switch status	0= normally open 1= normally closed	0
F3	Fan status with compressor off	0 = Fans run continuously 1 = Fans only run when compressor is working	1
F4	Fan pause during defrost	0 = Fans run during defrost 1 = Fans do not run during defrost	1
dE	Sensor presence If the evaporator sensor is disabled defrosts are carried out cyclically with period d0: defrosting ends when an external device trips and closes the remote defrost contact or when time d3 expires.	0 = evaporator sensor present 1 = no evaporator sensor	0
d1	Defrost type , cycle inversion (hot gas) or with heater elements	1= hot gas 0= element	0
Ad	Network address for connection to the TeleWIN supervision system	0 - 31	0
Ald	Minimum and maximum temperature signalling and alarm display delay	1...240 min	120 min
C1	Minimum time between shutdown and subsequent switching on of the compressor.	0...15 min	0 min

CAL	Cold room sensor value correction	-10...+10	0
Pc	Compressor protection contact status	0 = NO 1 = NC	0 = NO
doC	Compressor safety time for door switch: when the door is opened the evaporator fans shut down and the compressor will continue working for time doC , after which it will shut down.	0...5 minutes	0
Fst	FAN shutdown TEMPERATURE The fans will stop if the temperature value read by the evaporator sensor is higher than this value.	-45...+45°C	+45°C
Fd	Fst differential	0...+10°C	2°C
tA	NO – NC alarm relay switching	0=activates when alarm is on 1=deactivates when alarm is on	1
AU	Auxiliary/alarm relay control (only on version with relay fitted)	0=alarm relay 1=manual auxiliary relay controlled via AUX key 2= automatic auxiliary relay managed by StA temp. setting with 2°C differential 3= relay disabled / TeleWIN function 4= pump down function (see 5.15) 5= free voltage contact for condensing unit (AUX relay and compressor relay in parallel)	0
StA	Temp. setting for aux. relay	-45...+45°C	0
In1	Man in cold room alarm Select input INP1 on the board as <i>compressor protection alarm</i> or as <i>man in cold room alarm</i> (contact NC).	0 = compressor protection 1 = man in room alarm	0
reL	Software release	indicates software version	Read only

5.11 SWITCHING ON THE ECP200 EXPERT ELECTRONIC CONTROLLER

After wiring the electronic controller correctly, power up at 230 V AC; the display panel will immediately emit a beep and all the LEDs will come on simultaneously for a few seconds.

5.12 COMPRESSOR ACTIVATION/DEACTIVATION CONDITIONS

The **ECP200 EXPERT** controller activates the compressor when cold room temperature exceeds setting+differential (r0); it deactivates the compressor when cold room temperature is lower than the setting.

MANUAL DEFROSTING**5.13**

To defrost just press the dedicated key (see section 5.2) to activate the elements relay. Defrosting will not take place if the end-of-defrost temperature setting (d2) is lower than the temperature detected by the evaporator sensor. Defrosting ends when the end-of-defrost temperature (d2) or maximum defrost time (d3) is reached.

HOT GAS DEFROSTING**5.14**

Set parameter d1 =1 to defrost in cycle inversion mode.

The compressor relay and defrost relay are activated throughout the defrost phase.

To ensure proper control of the system the installer must use the defrost output: this must allow opening of the cycle inversion solenoid valve and closure of the liquid solenoid valve. For capillary systems (without thermostat valve) it is only necessary to control the cycle inversion solenoid valve via the defrost relay control.

PUMP DOWN FUNCTION**5.15**

Pump down function is activated when parameter AU=4 (only for version with AUX/Alarm relay).

Connect pump down pressostat on the digital input 1-3. The compressor is directly controlled by pressostat.

Connect evaporator solenoid valve on the AUX relay. The solenoid is controlled directly by thermostat.

CHAPTER 6: OPTIONAL KITS**6.1****TeleWIN / TeleNET MONITORING/SUPERVISION SYSTEM**

For connections regarding the **TeleWIN-TeleNET** / monitoring/supervision system see APPENDIX A.3 a page 26 of this manual and, for the ECP200 EXPERT jumper JP2 as described in 6.2 ON page 22.



ALARM RELAY / TeleWIN-TeleNET SWITCHING

6.2

Fig. 1: Open the front of the box as described in Chap. 2.3 (page 7): rotate it downwards 180° to gain access to the electronic board.

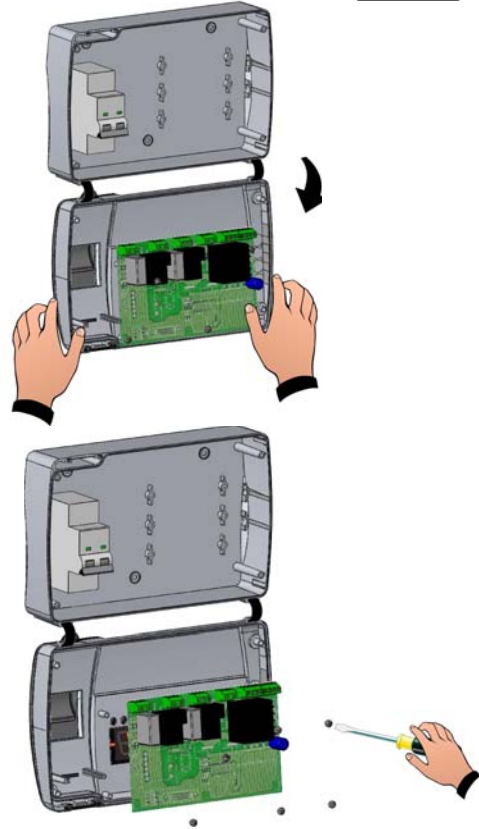

Fig.2: Undo the 6 CPU board fixing screws: remove the board from the frontal part of the box in ABS.

Fig. 3: Remove the jumper from JUMPER JP2.

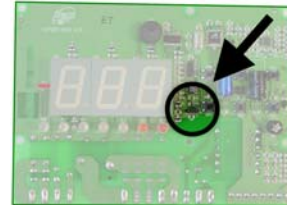
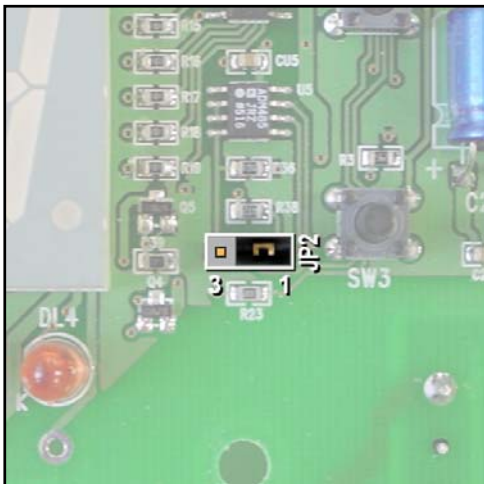
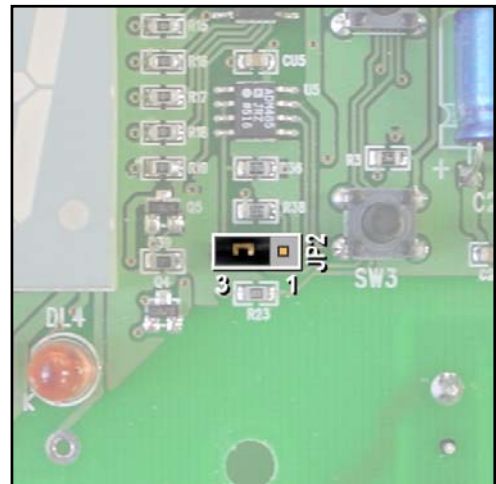

Fig. 4: Insert the jumper in JUMPER JP2 in position 2-1 to select **Alarm relay**
Or position 3-2 to select **TeleWIN/TeleNET**.

AUX. ALARM RELAY**TeleWIN / TeleNET**

CHAPTER 7: TROUBLESHOOTING

7.1

TROUBLESHOOTING

In the event of any anomalies the ECP200 EXPERT warns the operator by displaying alarm codes and sounding the warning buzzer inside the control panel. If an alarm is tripped the display will show one of the following messages.

ALARM CODE	POSSIBLE CAUSE	SOLUTION
E0	<i>Cold room temperature sensor not working properly</i>	<ul style="list-style-type: none"> • Check that cold room temperature sensor is working properly • If the problem persists replace the sensor
E1	<i>Defrost sensor not working properly</i> (In this case defrosts will last time d3)	<ul style="list-style-type: none"> • Check that defrost sensor is working properly • If the problems persists replace the sensor
E2	<i>Eeprom alarm</i> An EEPROM memory alarm has been detected (All outputs except the alarm one are deactivated)	<ul style="list-style-type: none"> • Switch unit off and back on
E8	<i>Man in cold room alarm</i>	<ul style="list-style-type: none"> • Reset the alarm input inside the cold room
Ec	<i>Compressor protection tripped</i> (e.g. thermal protection or max pressure switch) (All outputs except the alarm one – where applicable – are deactivated)	<ul style="list-style-type: none"> • Check that compressor is working properly • Check compressor absorption • If the problem persists contact the technical assistance service
Temperature shown on display is flashing	<i>Minimum or maximum temperature alarm.</i> The temperature inside the cold room has exceeded the min. or max. temperature alarm setting (see variables A1 and A2, user programming level)	<ul style="list-style-type: none"> • Check that the compressor is working properly. • Sensor not reading temperature properly or compressor start/stop control not working.

APPENDICES**A.1****EC declaration of conformity****COSTRUTTORE / MANUFACTURER**

PEGO SRL Via Piacentina,6b 45030 Occhiobello (RO) - ITALY -

DENOMINAZIONE DEL PRODOTTO / NAME OF THE PRODUCT

MOD.: ECP200 EXPERT

IL PRODOTTO E' CONFORME ALLE SEGUENTI DIRETTIVE CE/THE PRODUCT IS IN CONFORMITY WITH THE REQUIREMENTS OF THE FOLLOWING EUROPEAN DIRECTIVES:

- 73/23 CEE** Direttiva del Consiglio per l'unificazione delle normative dei Paesi CEE relativa al materiale elettrico destinato ad essere utilizzato entro certi limiti di tensione e successive modificazioni
- 73/23 EEC EC Directive on unification of laws of the Member States relating to electrical equipment employed within certain voltage limits and subsequent amendments
- 89/336 CEE** Direttiva del Consiglio per l'unificazione delle normative dei Paesi CEE relativa alla compatibilità elettromagnetica e successive modificazioni
- 89/336 EEC EC Directive on unification of the laws of the Member States relating to electro-magnetic compatibility and subsequent amendments
- 93/68 CEE** Direttiva del consiglio per la marcatura CE del materiale elettrico destinato ad essere utilizzato entro taluni limiti di tensione.
- 93/68 EEC EC Directive on application of CE logo to electrical equipment for use within certain voltage limits.

**LA CONFORMITA' PRESCRITTA DALLE DIRETTIVE E' GARANTITA DALL' ADEMPIMENTO A TUTTI GLI EFFETTI DELLE SEGUENTI NORME:
CONFORMITY WITH THE REQUIREMENTS OF THIS DIRECTIVE IS TESTIFIED BY COMPLETE ADHRENCE TO THE FOLLOWING STANDARDS:**

NORME ARMONIZZATE / HARMONIZED EUROPEAN STANDARDS

EN 61000-6-1 EN 61000-6-3 EN 60335 - 1

ECP200 EXPERT WIRING DIAGRAM

A.2

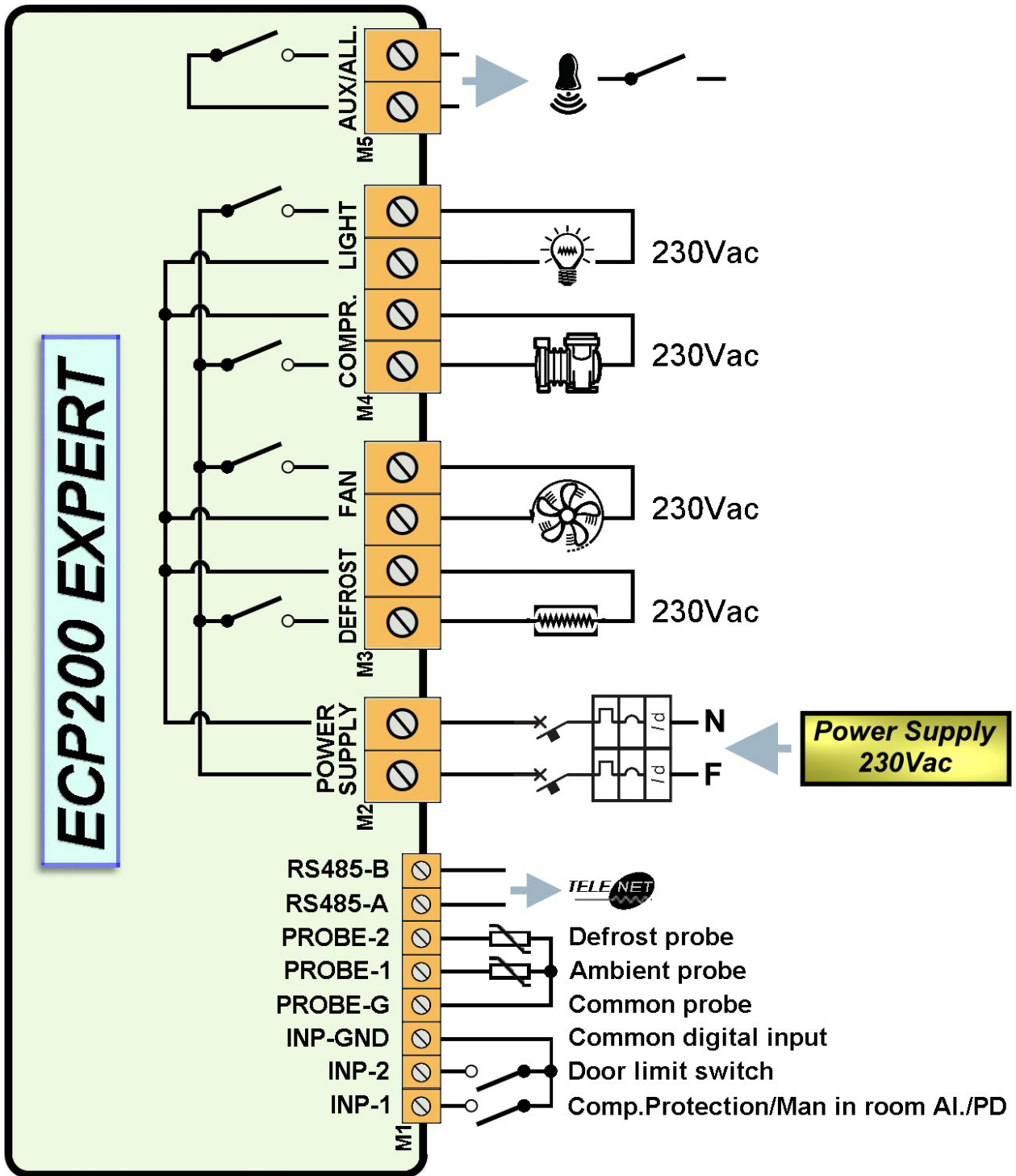

A.3 TeleWIN / TeleNET NETWORK CONNECTION WIRING DIAGRAM

BEFORE CONNECTING UP COMMUTATE THE ALARM RELAY / TELEWIN SWITCHING FUNCTION VIA DIP-SWITCH AS INDICATED CAP. 6.2



**Morsettiera di collegamento TeleWIN-TeleNET
Terminal block TeleWIN-TeleNET connection**

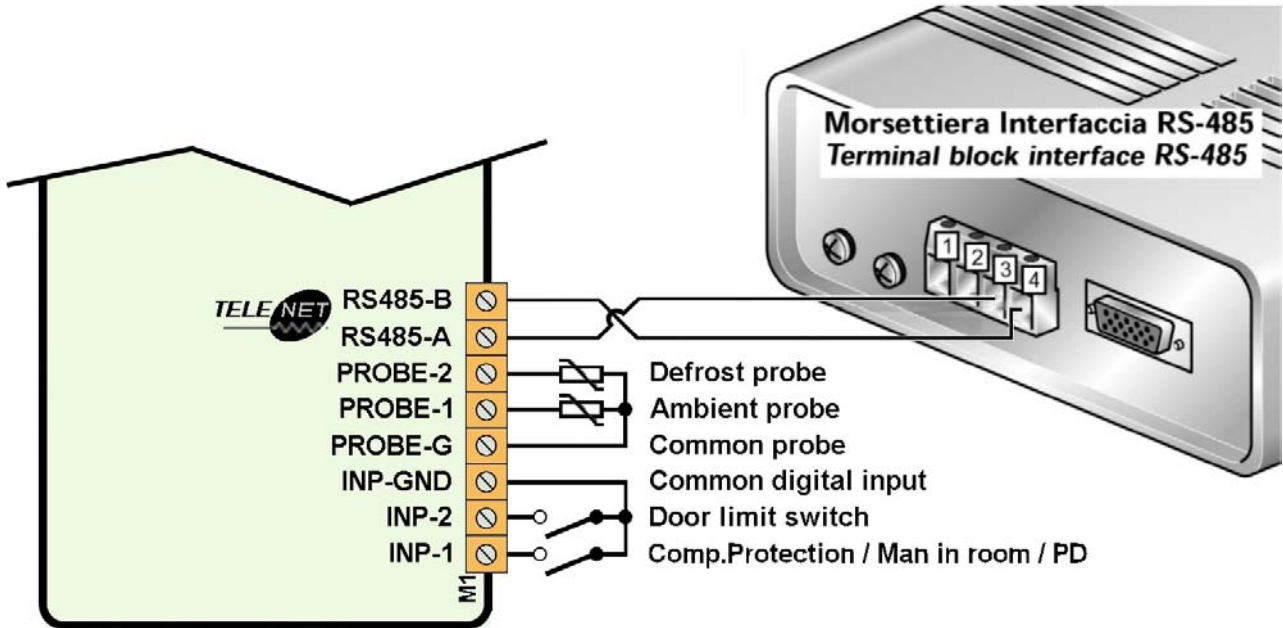

**Interfaccia RS-485
Interface RS-485**

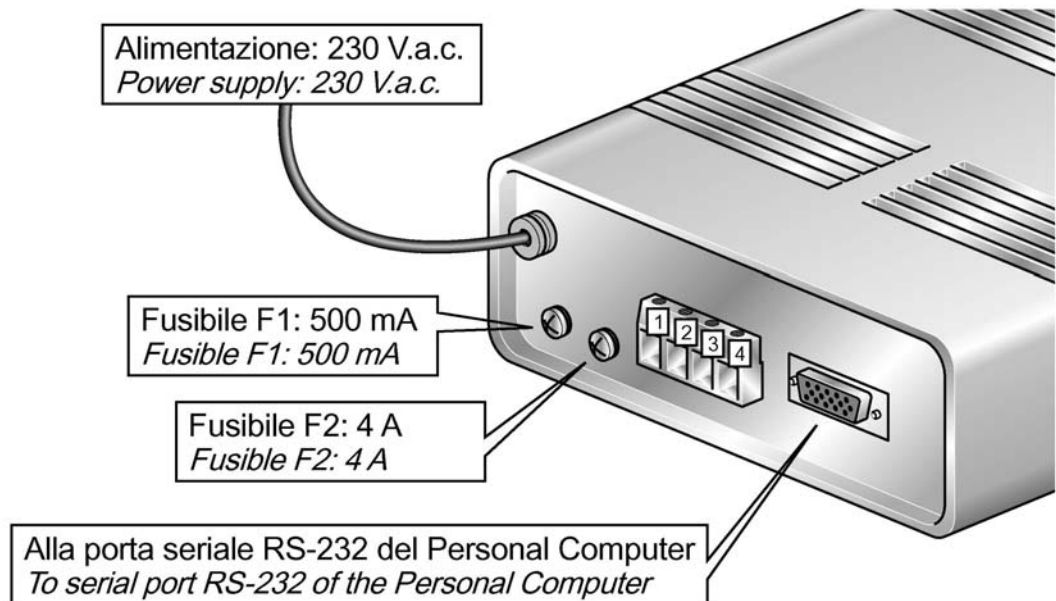

A.4

Part list

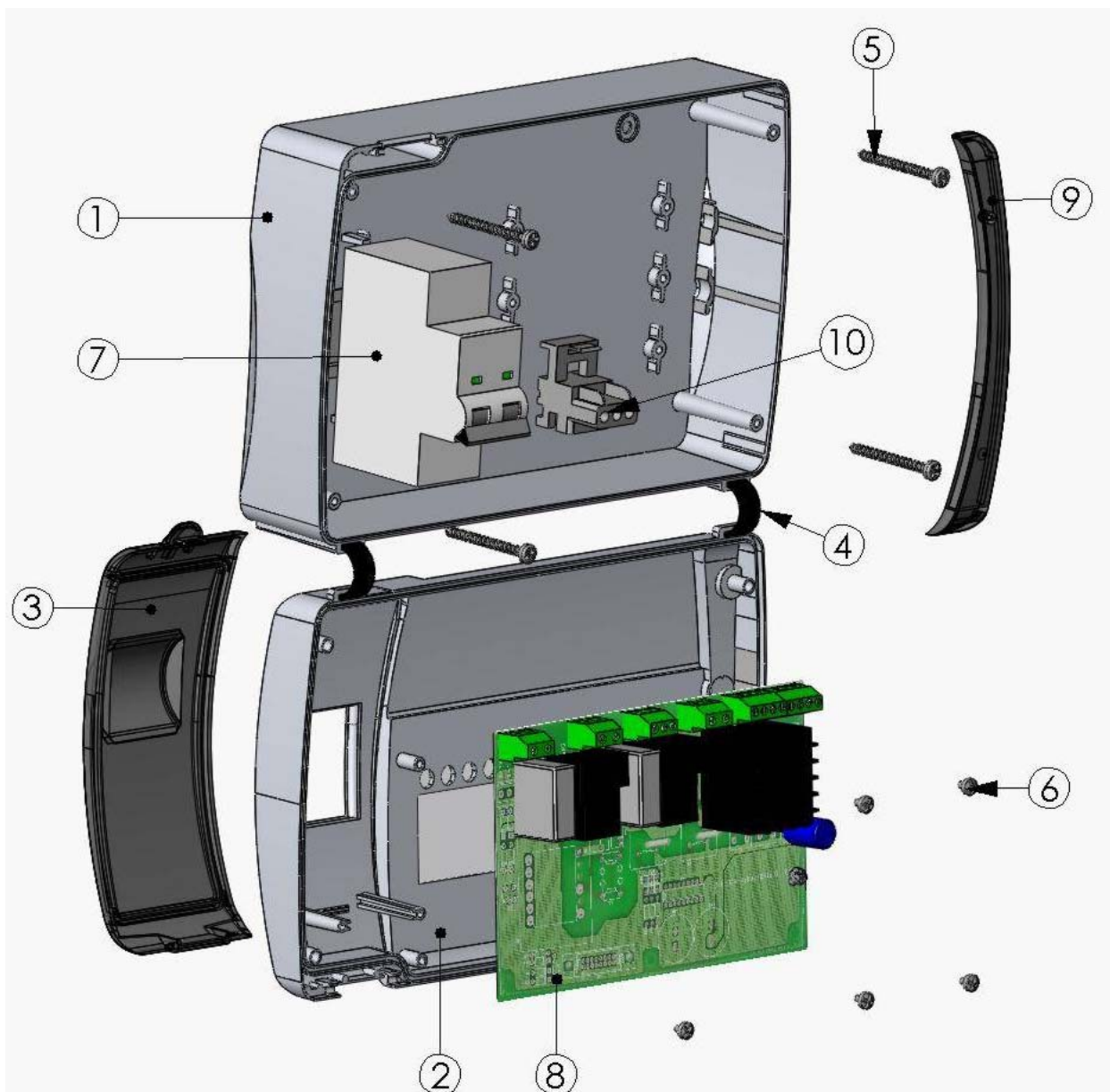

KEY	
REF.	DESCRIPTION
1	BOX REAR IN ABS
2	BOX FRONT IN ABS
3	FRONT COVER IN TRANSPARENT POLYCARBONATE
4	BOX FRONT OPENING HINGE
5	BOX CLOSURE SCREWS
6	BOARD FIXING SCREWS
7	MAGNETO-THERMAL CUT-OUT / POWER BREAKER
8	CPU BOARD
9	POLYCARBONATE SCREW COVER
10	TERMINAL FOR EARTH CONNECTIONS



PEGO S.r.l.

Via Piacentina, 6/b

45030 OCCHIOBELLO –ROVIGO-

Tel : 0425 762906

Fax: 0425 762905

www.pego.it

e-mail: info@pego.it

Distributore: